

CEMENT FIBRE DECKING

# CDECK

BROCHURE

## CEMENT FIBRE

---

At Fire Deck, we're proud to present our market-leading cement fibre decking. The classic look of timber is combined with the strength and durability of cement fibre. Designed to withstand the toughest conditions, it's the go-to for any outdoor project, from garden revamps to balcony updates. With its compliance to A1 fire safety standards (EN 13501-1:2018), CDECK offers both style and peace of mind.

Our decking is a cut above traditional wood. It resists splintering and decay, ensuring it looks great for years. With anti-slip properties maintaining traction under wet conditions, CDECK is a trustworthy option for both domestic and commercial settings.

Safety is key with CDECK. Our non-slip surface is perfect for keeping your footing, even when it's wet, and the fire-resistant nature of our decking means your space is not just stylish, but secure too.

The benefits don't stop there. CDECK arrives pre-sealed for extra convenience, ideal for balconies, terraces, and high-rise exteriors. Its resistance to water damage means it's a long-term investment for your home, guaranteeing long-term structural integrity.

Environmentally conscious? So are we. CDECK has a lower carbon footprint compared to alternatives like aluminium decking and is fully recyclable.

Opting for CDECK means choosing a decking solution that's not just high-performing but also blends natural beauty with toughness. Experience the perfect mix of style and durability with CDECK.

### WHAT IS CEMENT FIBRE?

Cement fibre decking is manufactured through a precise process that combines the strength and durability of cement with the flexibility and resilience of fibres.

The primary components of cement fibre decking include Portland cement, sand, and cellulose fibres. The cellulose fibres, often derived from recycled paper or wood pulp, are treated to enhance their durability and resistance to decay.

The result is a high-performance, durable, and aesthetically versatile product suitable for a wide range of outdoor applications, from residential decking to commercial landscaping projects.

**FEATURES AT A GLANCE:**

- A1 fire rating for ultimate safety.
- Natural timber effect for a timeless look.
- Hard-wearing cement fibre for unmatched durability.
- Superior slip resistance for safety.
- Feels and sounds solid underfoot.
- Quiet due to solid construction.
- Stain-resistant and easy to clean.
- Securely fixed to an aluminium substructure to withstand wind uplift.
- Can be cut like hardwood, using a PCD cement fibre blade.
- Maintains a stable temperature.
- Remains cool to touch in direct sunlight.
- Immune to warping, twisting, or rotting.
- 30-year limited warranty.
- Designed to last 60 years.



# BENEFITS

## PRODUCT CHARACTERISTICS

### HIGH STRENGTH

CDECK is durable and rugged, with high load bearing properties, making it suitable for high traffic communal areas.

With resistance to positive and negative pressure, it withstands wind uplift and is resistant to cracking under high temperature weather changes.

### NON-COMBUSTIBLE MATERIALS

Combustion performance meets the requirements of EN 13501-1:2018 classification. CDECK meets the highest classification of A1FL.

### WEATHERABILITY

Through 100 freeze thaw cycles, 50 hot rain cycles, 56 day hot water immersion test, water resistance, acid resistance and alkali resistance test, the boards meet the requirements of JC/Y 'Fibre Cement Plate Part 1: Asbestos free Fibre Cement Plate' A product standard, and can be used in severe cold and bad climate areas.

### ANTI-SLIP RESISTANCE

CDECK has excellent anti-slip properties, making it safe and a good choice for high traffic areas in wet conditions. CDECK is suitable for use in areas with high rainfall, including marinas and beach fronts.

### ENVIRONMENTALLY FRIENDLY

CDECK is 100% recyclable. Our products don't contain asbestos or formaldehyde, and meet the requirements of national class A decorative materials standards.

### RICH IN COLOUR

For the most natural results, our boards have colour variations with a beautiful cedar texture. We do not compromise on the look, with close attention to detail. CDECK boards are not painted, they are coloured throughout the core.

The main substrates of cement fibre boards are imported Portland cement and quartz powder. We add additional special materials like lime and cellulose, and after molding with pressurised steaming, and surface treatment, it becomes a decking board which is high-strength, easy to cut and drill with anti-corrosion, anti-worm moths, anti-mould, with strong weather resistance and a long life span. CDECK provides a good step experience and visual satisfaction.

Due to the exceptional properties of CDECK cement fibre boards, they may be used in many applications, including but not limited to, parks, marinas, balconies, community walkways, roof terraces, seaside beach fronts, gardens, and swimming pool areas.





**FIRE-RESISTANT: CLASS A1**  
Cement fibre boards are fully fire resistant.



**WIND RESISTANT**  
In outdoor environments, CDECK is a wind-resistant decking system. It can withstand both positive pressure (uplift) and negative pressure (suction).



**STAIN RESISTANT & LOW MAINTENANCE**  
CDECK is an easy-to-clean outdoor solution. It is also perfect for renovating patios and terraces, without having to worry about its maintenance. It is impregnated from factory with Dry Treat Premium Impregnating Sealer which should last for many years.



**HIGH MECHANICAL & ABRASION RESISTANCE**  
A product with a very high breaking strength and outstanding resistance to surface abrasion.



**NO WARP TWIST OR ROT**  
CDECK is durable and will not warp, twist or rot. It will not easily scratch or dent.



**COMMITTED TO THE ENVIRONMENT**  
CDECK is 100% recyclable.



**ANTI-SLIP PROPERTIES**

	Dry	Wet
Along the grain	60	41
Against the grain	62	54



**WARRANTY**  
30 year limited warranty.



**RESISTANCE TO FROST, ICE & TEMPERATURE CHANGES**  
It can also withstand sharp temperature changes: it does not become deformed and neither do the boards expand.



**SUITABLE FOR RESIDENTIAL OR COMMERCIAL AREAS (HIGH TRAFFIC)**  
CDECK decking is suitable for use in areas subject to high pedestrian traffic, thanks to its high durability and strength.



**REMOVABLE SYSTEM**  
CDECK parts are installed using a customized clip system. This results in a fast and agile installation, speeding up the install.



**ACCESSORIES**  
The range of CDECK products offers the possibility of combining CDECK boards with other elements that solve different technical aspects like steps.



**AESTHETICALLY PLEASING**  
CDECK has a 3D authentic woodgrain finish and is coloured through to the core, so you can make cuts and joins to suit your project.



**DURABILITY & RESISTANCE TO ULTRA-VIOLET RAYS**  
CDECK is made of top-quality cement fibre, guaranteeing a high breaking strength and resistance to ultra-violet rays.

## FEATURES

---

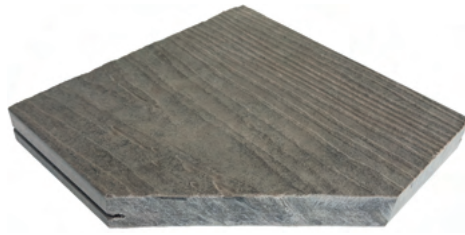

FRESHLY CUT, UNSEALED EDGE

### **COLOURED TO THE CORE**

Our boards are not painted, they are coloured to the core, so that you can cut them to suit your needs, without compromising on the aesthetic quality



### **ARRIVES SEALED**

Arrives sealed with protection against UV rays, ready for installation



### **SUSTAINABLE**

100% Recyclable



### **STOCKED IN THE UK**

We hold stock of Quartz Grey in our UK warehouse, ready to ship quickly for your projects

# VARIATIONS & SIZES

# CDECK

**LENGTH:** 2440mm

**WIDTH:** 200mm

**THICKNESS:** 25mm

**WEIGHT:** Per board 21Kg

**WEIGHT:** Per sqm 43Kg

**FIRE CLASSIFICATION:** A1fl-s1



**SILK GREY**  
Made to Order  
Minimum 650sqm

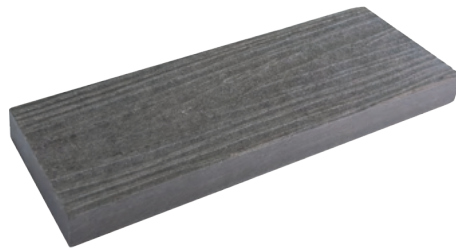

**DUSTY GREY**  
Made to Order  
Minimum 650sqm

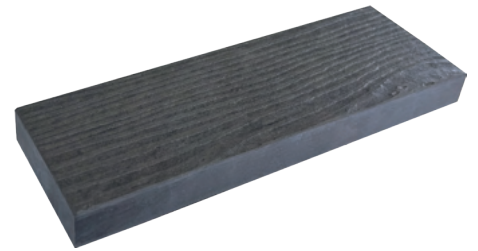

**QUARTZ GREY**  
Stock Colour in the UK

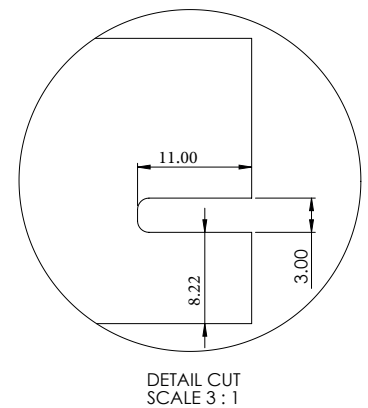
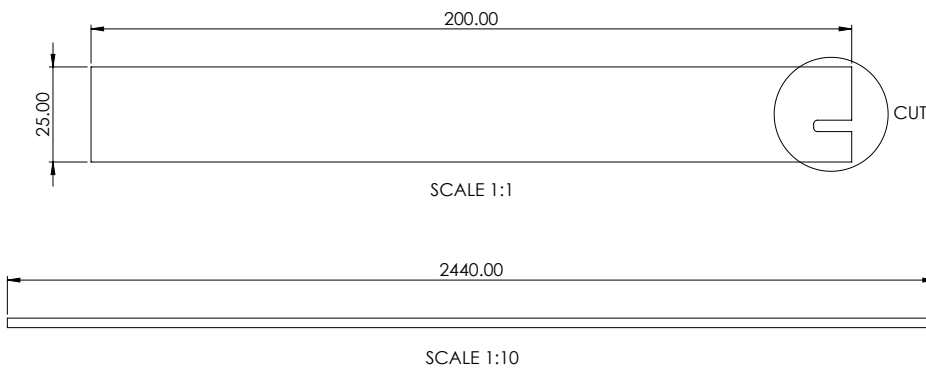

# PROJECTS

PROJECT: ST JAMES SQUARE NOBLE HOUSE    LOCATION: LONDON, UK    MATERIAL: CDECK QUARTZ GREY





# CDECK

PROJECT: PRIVATE · LOCATION: HACKNEY, LONDON · MATERIAL: CDECK DUSTY GREY



PROJECT: MARQUE HOUSE · LOCATION: CAMBRIDGE · MATERIAL: CDECK DUSTY GREY

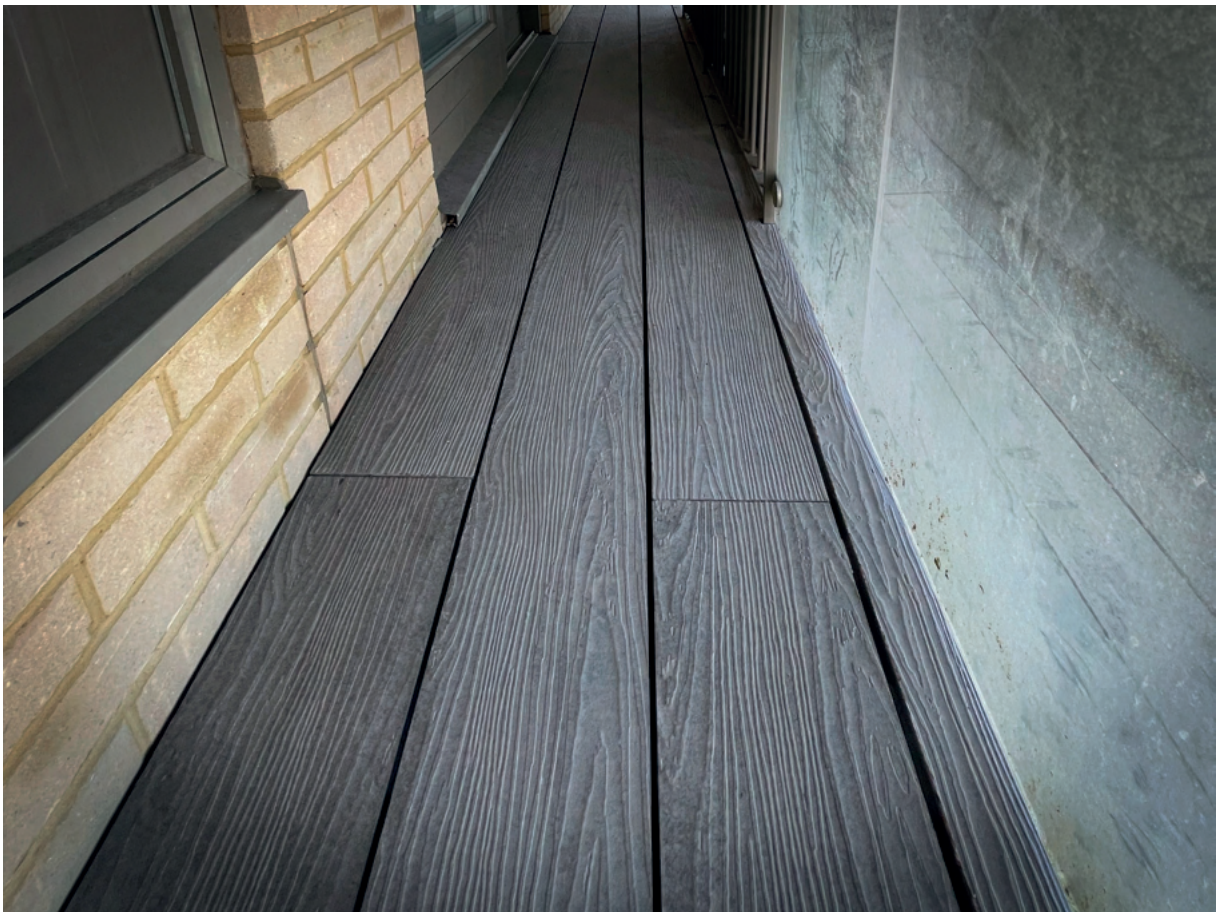

# PROJECTS

---

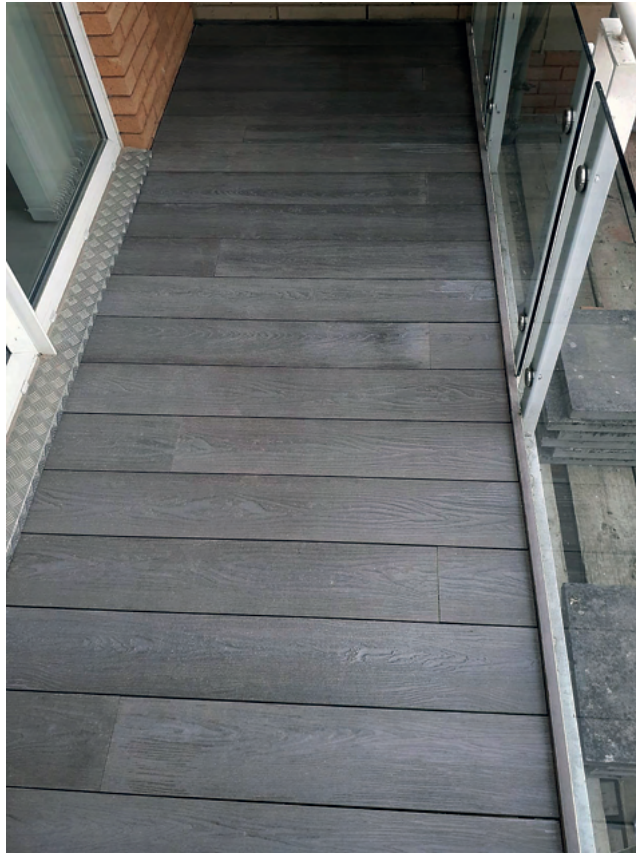

PROJECT: PRIVATE · LOCATION: CARDIFF BAY · MATERIAL: QUARTZ GREY

10 | CDECK



PROJECT: PENTHOUSE · LOCATION: KENSINGTON · MATERIAL: CDECK QUARTZ GREY

# PROJECTS

---

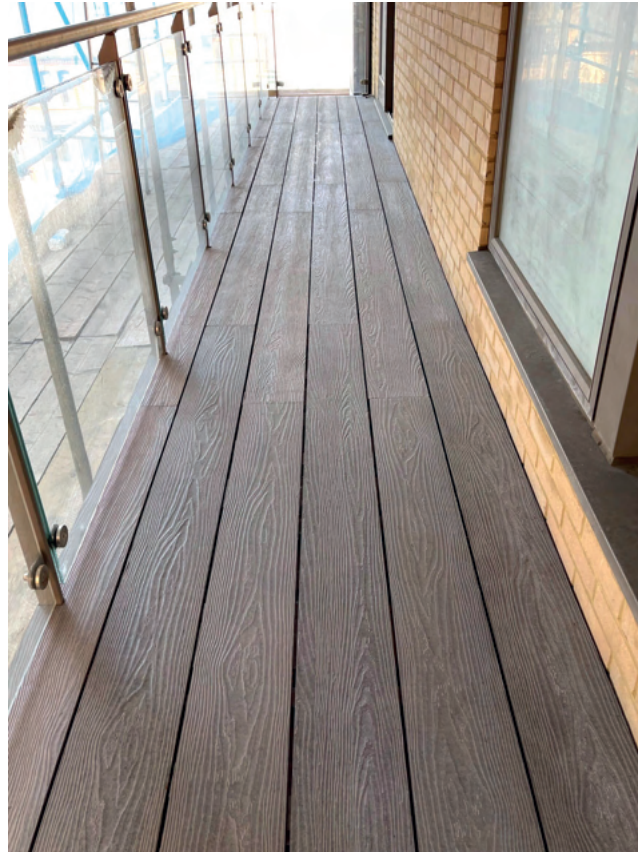

PROJECT: MARQUE HOUSE · LOCATION: CAMBRIDGE  
MATERIAL: CDECK DUSTY GREY



PROJECT: WICK LANE · LOCATION: LONDON  
MATERIAL: CDECK DUSTY GREY

PROJECT: WICK LANE · LOCATION: LONDON · MATERIAL: CDECK DUSTY GREY



# CLEANING & MAINTENANCE

Our CDECK cement fibre board has been produced and tested to the updated British building regulation standards BS 8579:2020 design of balconies and terraces. CDECK cement fibre board will never burn, rot, rust, or warp. With simple and regular care so you can relax in the knowledge that your CDECK is safe and sound for many years to come.

Here are a few simple tips to ensure your CDECK remains in optimum condition.

## DO'S



Keep your deck free of dirt and debris by regular sweeping (at least every 2 weeks) with a soft brush.



Keep your deck in optimal condition by cleaning regularly with clean water and a mild detergent if necessary. Clean, wet surfaces can be allowed to air dry or may be wiped dry with a soft cloth.



Use furniture with rubber or plastic feet to prevent unnecessary scratching of the decking surface.



Try to lift furniture or planters rather than drag them across the deck surface.



Check your decking carefully once a year to ensure no fixings are working loose, and simply tighten them using the appropriate driver bit if necessary.



Use your balcony and deck safely and enjoy!

## DON'T



Use sharp or abrasive materials to clean your deck (e.g. wire wool, abrasive papers or scrubbing tools). This may cause scratching of the coating which will affect the appearance.



Use abrasive salt grit for de-icing purposes. Instead, use easily soluble salt.



Use aggressive acid or alkaline chemical to clean your deck.



Use furniture with metal feet which can scratch the decking if dragged across the surface.



Use oil/wax sealants, coatings, or polishes on the decking to become slippery, especially when wet.

## IF

**SCRATCHES OR OTHER SURFACE DAMAGE:** if your decking becomes damaged or scratched, minor scratches or damage may be removed using a medium grit abrasive paper. Damaged deck boards may be removed and replaced if necessary but always check with your building manager or landlord if you live in a multi-occupancy apartment block. CDECK accepts no responsibility for the unsafe removal of deck boards from balcony environments.

If in any doubt please Contact Us to ask for advice.

**LOSES IT'S STAIN RESISTANCE:** Your CDECK is impregnated from factory with Dry Treat Premium Impregnating Sealer which should last for many years. When boards have been cut on installation, we recommend that the ends that have been cut are re sealed to make sure the boards are fully protected. When boards have been cut you have cut off the end that has been sealed in the factory and is now exposed and not sealed. We recommend applying a coat of the water-based sealer every three years or as desired to maintain the deck in optimum condition and easier to clean. No sealer will last forever. Dry Treat Premium Impregnating Sealer is fast and easy to apply with a roller or cloth.

# TECHNICAL DATA



## FIRE PROOF A1 RATED NON-COMBUSTIBLE DECKING

### TECHNICAL PARAMETER

Density	
Density g/cm <sup>2</sup>	≥ 1.4
Moisture Absorption %	≤ 28
Wet Swelling Rate %	≤ 0.25
Combustibility Performance	Grade A1 Non-combustible
Impermeability	After 24 hour inspection, no water droplets were found
Weatherability	
Anti-Frozen	100 times frozen melting circle, no cracking, no layer
Hot Rain Test	Fifty hot rain cycles, no cracks and delamination on the plate surface
Hot Water Test	The ratio of saturated flexural strength to saturated flexural strength is greater than or equal to 70% after 56 days immersion at 60 degrees Celsius
Immersion Drying Test	After 50 cycles of drying, the saturated flexural strength ratio is greater than or equal to 70%
Mildew Resistance Test	Antifungal property grade 0
Water Resistance	After 30 days, no cracking, no layering, no falling off, no swelling and no colour change observed
Acid Resistance	After 15 days, no cracking, no layering, no falling off, no swelling and no colour change observed
Alkali Resistance	After 15 days, no cracking, no layering, no falling off, no swelling and no colour change observed
Environmental Protection Performance	
Non-Asbestos Test	It confirms to HJ/T223-2005 Standard and does not contain Asbestos
Radioactivity	Complying with GB6566-2021 Standard and meeting the requirements of Class A decorative materials. IRA is less than or equal to 1.0. Exposure index IR less than or equal to 1.0. Class A decorative materials, production, marketing and scope of application are unrestricted.
Mechanical Property	
Saturated flexural strength	≥13
Specification & Size	
Length (mm)	2440
Width (mm)	150 200
Thickness (mm)	25

## CONTRAST OF DECKING BOARD

PRODUCT CHARACTERISTICS	FIBRE CEMENT DECKING BOARD	ANTI-CORROSIVE WOOD DECKING BOARD	WOOD / BAMBOO PLASTIC DECKING BOARD
Main Components	Portland Cement, Quartz Floor	Wood, Preservative	Wood, Bamboo Fibre & Plastics
Environmental protection	Green environmental protection, asbestos free, formaldehyde free, non toxic, tasteless & recyclable	Toxic preservatives are corrosive, carcinogenic and consume a large amount of wood resources	Toxic substances are easily produced during processing, which consumes part of wood resources
Fire Resistance	Fire Resistance Class A1	Flammable, poor Fire Resistance	Fire proof grade B1, easy to soften at high temperature
Weatherability	Rainwater erosion resistance, aging resistance, 100 cycles of freeze thaw without damage, deformation & cracking	Weather resistance is poor, dry shrinkage, wet expansion, easy to deform, serious corrosion	Weather resistance is poor, easy to aging under sunshine, serious deformation
Moisture-proof & Moth-proof	Excellent	Commonly	Good
Rugged & Wear Resistant	Excellent	Poor	Good
Service Life	30 years	3 to 5 years	3 to 5 years
Cost Performance	High performance price ratio	Poor performance price ratio	Poor performance price ratio

## COMPOSITION, INFORMATION & INGREDIENTS

CHEMICAL NAME	PERCENT (BY WEIGHT)	CASE NO.	EC#	MITI NO.	KE-NO.
PORTLAND CEMENT	37%	65997-15-1	266-043-4	-	KE-29067
LIME	18%	1305-78-8	215-138-9	1-189	KE-04588
MICA	1.5%	12001-26-2	Unlisted	-	KE-25420
PERLITE	1.5%	93763-70-3	Unlisted	-	KE-05-0978
OTHER ADDITIVES	1.5%	N/A	N/A	N/A	215-171-9
QUARTZ	33.5%	14808-60-7	238-878-4	1-548	KE-29983
CELLULOSE	10%	9004-34-6	232-674-9	-	KE-05339



## FIRE DECK

Unit 18 Smeaton Road Portway West Business Park  
Andover Hampshire SP10 3LF

T 01264 311 113

[www.firedeck.uk](http://www.firedeck.uk)

Fire Deck reserves the right to partially or totally cancel or modify any of the colours, formats, references and technical specifications contained in this catalogue. The colours reproduced in this catalogue are intended as a guide and may vary in the original piece. The price codes, measures and references must be verified as there may be typographical errors.