



Operations & Maintenance Manual

Fire Deck - Fibre Cement Decking System



Wallbarn Ltd
Unit 16 Capital Business Centre
22 Carlton Road, South Croydon. CR2 0BS

IMS.T.967.v2

Phone : 020 8916 2222 Email : sales@wallbarn.com Website : www.wallbarn.com



The Complete Class A Decking System

Fire Deck - Fibre Cement Decking

Product Description

Fire Deck - Fibre Cement Decking board has been produced and tested to meet the updated British building regulation standards, BS 8579:2020, for the design of balconies and terraces. It is a highly durable material that will never burn, rot, rust, or warp. This system is particularly well-suited for commercial areas, designed to handle public weight loads with ease.

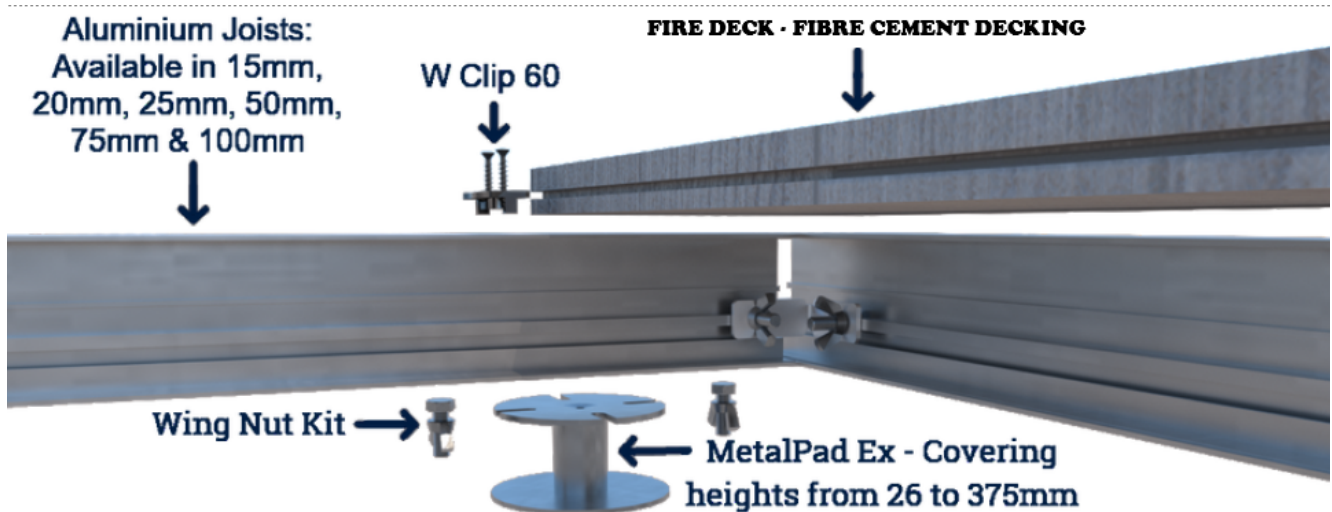

Wallbarn Ltd
Unit 16 Capital Business Centre
22 Carlton Road, South Croydon. CR2 0BS

IMS.T.967.v3

Phone : 020 8916 2222 Email : sales@wallbarn.com Website : www.wallbarn.com



Product Characteristics

High Strength - The board has high strength, saturated flexural strength is greater than or equal to 13MPA.

Non-combustible Materials - Combustion performance meets the requirements of GB8624- 2012 Classification of Combustion Performance of Building Materials and Products, the highest level grade A1 requirement.

Weatherability - Through 100 freeze thaw cycles, 50 hot rain cycles, 56 day hot water immersion test, water resistance, acid resistance and alkali resistance test, the Board meets the requirements of JC/Y 'Fibre Cement Plate Part 1: Asbestos free Fibre Cement Plate' A product standard, and can be applied to severe cold and bad climate areas.

Anti-slip, grinding resistance - High density inorganic Fibre Cement Boards with crystal structure of tobermorite. It has good anti-slip and grinding resistance capabilities, according to the test result. It meets all the requirements which national standard had mentioned.

Environment protection and energy saving - Products do not contain asbestos, no radioactivity, meet the requirements of national class A decorative materials standards, no formaldehyde release. Obtained the green labelling certificate of environmental signs issued by the National Environmental Protection Administration.

Fire Testing and Classification - Class A – as per EU COMMISSION DECISION of 4 October 1996 establishing the list of products belonging to Classes A 'No contribution to fire' provided for in Decision 94/61 1/EC implementing Article 20 of Council Directive 89/106/EEC on construction products.



Physical and Chemical Properties

Density	
Density g/cm ²	≥ 1.4
Moisture Absorption %	≤ 28
Wet Swelling Rate %	≤ 0.25
Combustibility Performance	Grade A Non-combustible
Impermeability	After 24 hour inspection, no water droplets were found
Weatherability	
Anti-Frozen	100 times frozen melting circle, no cracking, no layer
Hot Rain Test	Fifty hot rain cycles, no cracks and delamination on the plate surface
Hot Water Test	The ratio of saturated flexural strength to saturated flexural strength is greater than or equal to 70% after 56 days immersion at 60 degrees Celsius
Immersion Drying Test	After 50 cycles of drying, the saturated flexural strength ratio is greater than or equal to 70%
Mildew Resistance Test	Antifungal property grade 0
Water Resistance	After 30 days, no cracking, no layering, no falling off, no swelling and no colour change observed
Acid Resistance	After 15 days, no cracking, no layering, no falling off, no swelling and no colour change observed
Alkaline Resistance	After 15 days, no cracking, no layering, no falling off, no swelling and no colour change observed
Environmental Protection Performance	
Non-Asbestos Test	It conforms to HJ/T223-2005 Standard and does not contain Asbestos
Radioactivity	Complying with GB6566-2021 Standard and meeting the requirements of Class A decorative materials. IRA is less than or equal to 1.0. Exposure index IR less than or equal to 1.0. Class A decorative materials, production, marketing and scope of application are unrestricted.
Mechanical Property	
Saturated Flexible Strength	≥13
Specification & Size	
Length (mm)	2440
Width (mm)	150 & 200
Thickness (mm)	25

Wallbarn Ltd
 Unit 16 Capital Business Centre
 22 Carlton Road, South Croydon. CR2 0BS

IMS.T.967.v2

Phone : 020 8916 2222 Email : sales@wallbarn.com Website : www.wallbarn.com



Weight & Dimensions

BOARD DIMENSIONS : 25mm (H) x 200mm (D) x 2,440mm (L)

WEIGHT	
21 Kgs per Board	42 Kgs per sqm

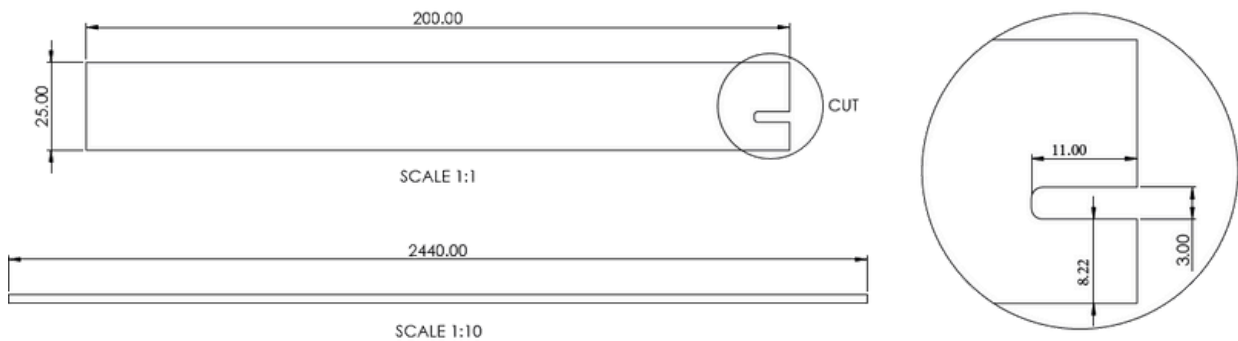

Composition & Materials

	PERCENT (BY WEIGHT)	CASE NO.	EC#	MITI NO.	KE-NO.
PORTLAND CEMENT	37%	65997-15-1	266-043-4	-	KE-29067
LIME	18%	1305-78-8	215-138-9	1-189	KE-04588
MICA	1.5%	12001-26-2	Unlisted	-	KE-25420
PERLITE	1.5%	93763-70-3	Unlisted	-	KE-05-0978
OTHER ADDITIVES	1.5%	N/A	N/A	N/A	215-171-9
QUARTZ	33.5%	14808-60-7	238-878-4	1-548	KE-29983

Wallbarn Ltd
 Unit 16 Capital Business Centre
 22 Carlton Road, South Croydon. CR2 0BS

IMS.T.967.v2

Phone : 020 8916 2222 Email : sales@wallbarn.com Website : www.wallbarn.com

Colours



SILK GREY
Made to Order
Minimum 650sqm



DUSTY GREY
Made to Order
Minimum 650sqm

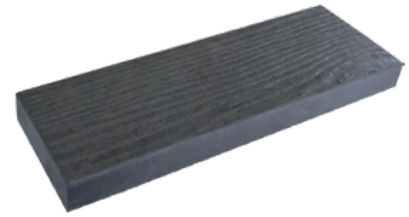

QUARTZ GREY
Stock Colour in the UK

Product Installation

You will require 5mm per metre fall on the subframe. A maximum span of 250mm is required between the first and second support joists, this also applies to the second to last and last joists (see diagram 1)



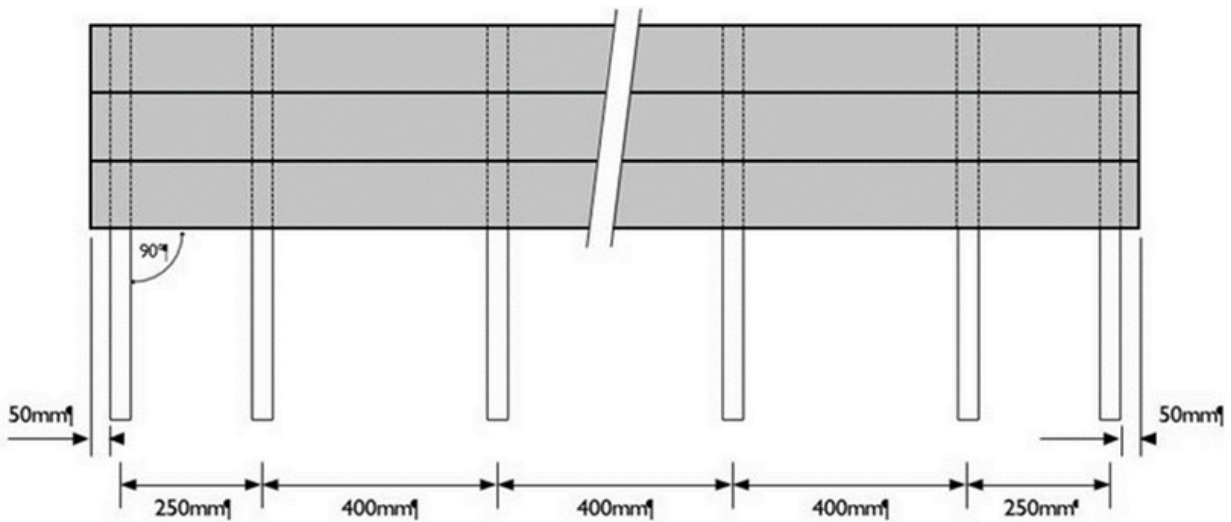

- A maximum of 400mm centres is recommended for all other joists.
- A maximum overhang of 50mm is permitted for the ends of the deck.

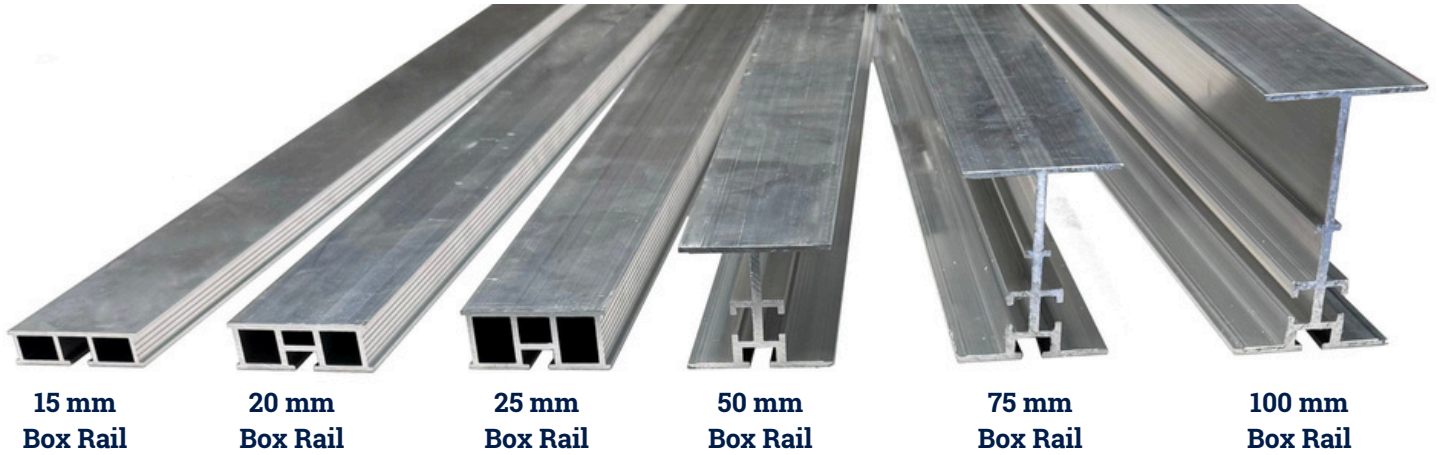

Aluminium Box Rails & I-Plus Joists



Physical & Chemical Properties

	15mm Box Rail	20mm Box Rail	25mm Box Rail	50mm I- Plus Beam	75mm I-Plus Beam	100mm I- Plus Beam
Profile						
Material	ALUMINIUM 6063 T6					
Fire Classification	Class A1 BS EN 13501-1 2018					
Weight	0.90kg/m	0.99kg/m	1.99kg/m	1.61kg/m	1.92kg/m	2.19kg/m
Height	15mm	20mm	25mm	50mm	75mm	100mm
Length	2,400mm	2,400mm	2,400mm	3,600mm	3,600mm	3,600mm



Recommended Pedestal Placement - Box Rail

Wallbarn Aluminium Box Rails/Joists are designed to achieve large spans despite their minimal height and lightweight. These products were independently tested for weight tolerance by Specialist Technical Services (U.K) Limited (STS- Group). See the Test Certificate : ([Appendix D](#))

The testing was conducted in accordance with BS 8579:2020, using the test standard method BS 8527:2020, targeting a load resulting in a 5mm deflection. The recommended spacings provided ensure even distribution of the pedestals along the chosen rail, effectively distributing the weight and reducing point loading.

Rail/Joist Height	Recommended maximum distance between pedestals	STS UK Test - Maximum distance between pedestals
15mm	600mm	600mm
20mm	600mm	600mm
25mm	800mm	800mm

15mm Box Rail/Joist

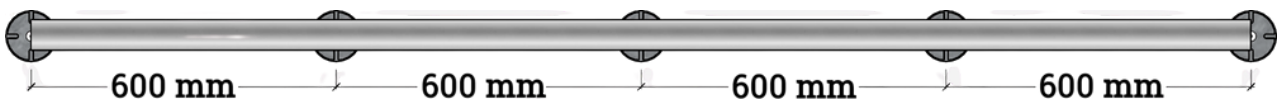

20mm Box Rail/Joist

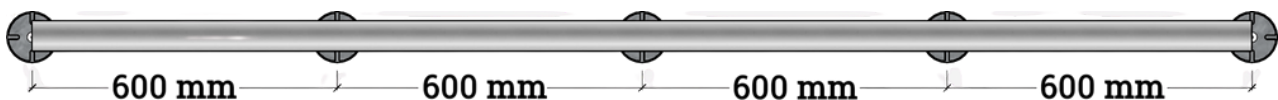

25mm Box Rail/Joist





Load Testing - Box Rail

Wallbarn Aluminium Box Rails/Joists have been independently tested by Specialist Technical Services (U.K) Limited to determine destructive load possible. 2 metre lengths of each rail were clamped on each end and a vertical compressive load was applied to the centre. ([See Test : Appendix E](#))

Starting with a 1.05kN force (approximately 107Kg), the rails bent to over 64mm without breaking. It was observed by the tester, that not only did the rails not break under this force but also regained their original shape after test had finished.

Test Product	STS UK Test - Load Obtained (kN)	STS UK Test - Maximum Displacement (mm)
15mm	1.05 (Approx. 107Kg)	68.77
20mm	1.06 (Approx. 108Kg)	65.87
25mm	1.58 (Approx. 161Kg)	64.63

** 1 Kilonewton (kN) is equal to 101.9716213 kilograms

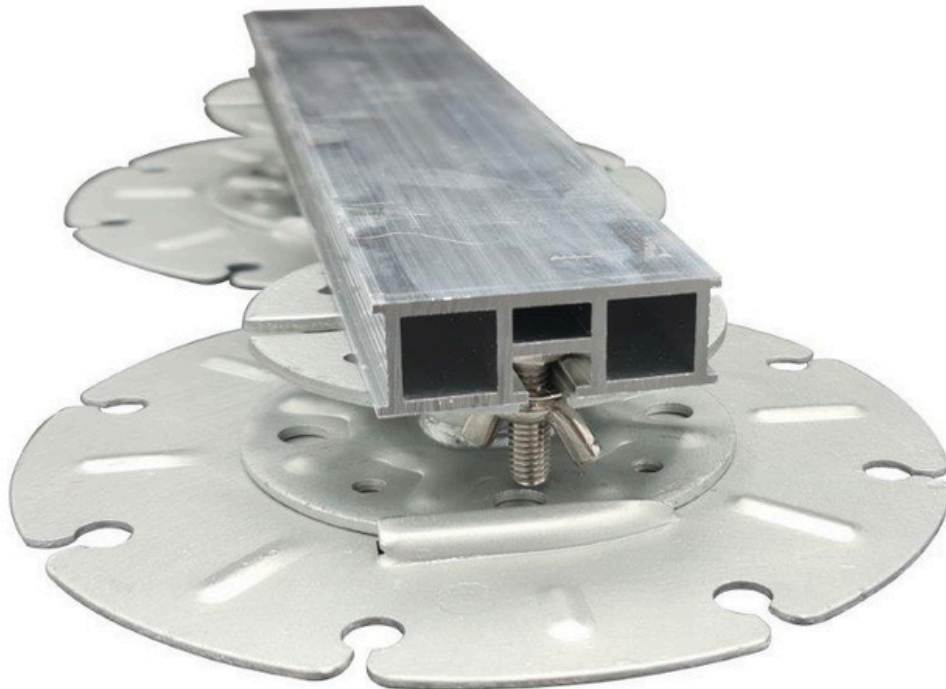

Wallbarn Ltd
Unit 16 Capital Business Centre
22 Carlton Road, South Croydon. CR2 0BS

IMS.T.967.v2

Phone : 020 8916 2222 Email : sales@wallbarn.com Website : www.wallbarn.com



Recommended Pedestal Placement - I-Plus Rail

Wallbarn Aluminium I-Plus Rails/Joists are capable of longer spans. These products were independently tested for weight tolerance by testing organisation, Specialist Technical Services (U.K) Limited. ([See Test : Appendix D](#)).

The testing was conducted in accordance with BS 8579:2020, using the test standard method BS 8527:2020, targeting a load resulting in a 5mm deflection. The recommended spacings provided ensure even distribution of the pedestals along the chosen rail, effectively distributing the weight and reducing point loading.

Rail/Joist Height	Recommended maximum distance between pedestals	STS UK Test - Maximum distance between pedestals
50mm	600mm	600mm
75mm	1,200mm	1,200mm
100mm	1,800mm	2,200mm

50mm Box Rail/Joist

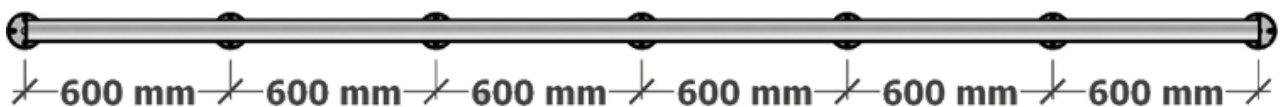

75mm Box Rail/Joist



100mm Box Rail/Joist

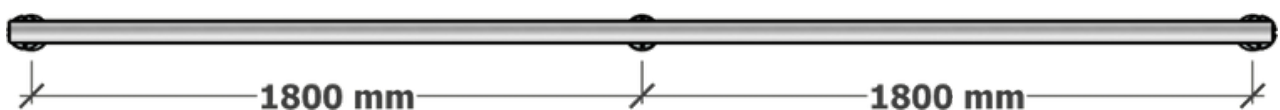



Load Testing - I-Plus Rail

Wallbarn Aluminium I-Plus Rails/Joists have been independently tested by Specialist Technical Services (U.K) Limited to determine destructive load possible. 2 metre lengths of each rail were clamped on each end and a vertical compressive load was applied to the centre. ([See Test : Appendix E](#))

The table below displays the force applied and the corresponding deflection achieved prior to failure.

Test Product	STS UK Test - Load Obtained (kN)	STS UK Test - Maximum Displacement (mm)
50mm	4.08 (Approx. 415Kg)	44.96
75mm	6.58 (Approx. 670Kg)	32.65
100mm	8.10 (Approx. 825Kg)	27.86

** 1 Kilonewton (kN) is equal to 101.9716213 kilograms



MetalPad Ex Pedestal

The pedestals are covered in Zintec 200 anti corrosion protective coating. This makes the pedestals suitable for external applications and also creates a barrier between the steel and the aluminium when used as part of the Fire Deck System.

- There are zero plastic or rubber components ensuring it's Class A rating.
- Rated Class A according to BS EN 13501-1:2018 and EC Decision 94/61 1/EC.
- Independently weight tested by STS UK to 49.86kN (Approximately 5,080Kg) - ([Go to Report](#)).
- Once the final height has been set, the locking nut must be wound to the solid stem and secured firmly. This locks the height in place and ensures the pedestal is achieving its full weight-bearing capacity, as verified through independent testing.

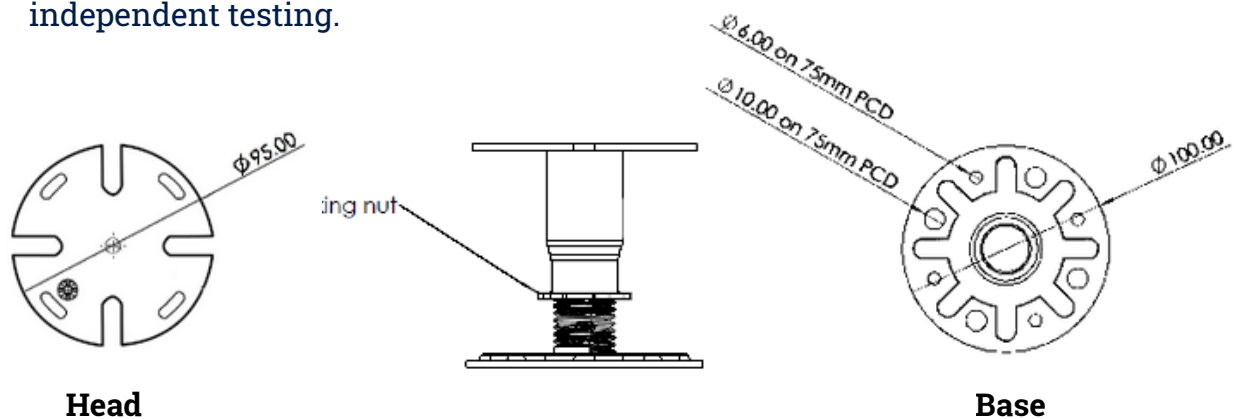

Height Range



Wallbarn Ltd

IMS.T.967.v2

Unit 16 Capital Business Centre
22 Carlton Road, South Croydon. CR2 0BS



MetalPad Ex Pedestal - Physical & Chemical Properties

MATERIAL	Mild Steel	EN 10152
PEDESTAL COATING	Zintec 200 corrosion protection coating	
THREADED STEM	Mild Steel Class 4:8	
FIRE CLASSIFICATION	Class A1 - EC Decision 96/603/EC BS EN 13501-1:2018	
BUILDING STANDARDS COMPLIANCE	Approved Document B (amended)	2022
	British Standard (balcony construction)	BS 8579
USE/PURPOSE	Suspended decking and paving projects on Balconies, Terraces, Flat Roof & Podium Decks.	
WEIGHT TOLERANCE	49.86kN (Approximately 5,080Kg) per unit	
WEIGHT TOLERANCE WITH SPREADER PLATE	70.69kN (Approximately 7,207Kg) per unit	
DURABILITY	MetalPad EX is manufactured for long-term performance and resistance to corrosion, exposure to elements and to UV rays	
WARRANTY	Limited warranty 15 years	
	Life span 50 years	
TOXICITY	These products are not classified as toxic	
HEADPIECE	95mm diameter with central hole 6mm diameter 4 x connection slots 10mm x 22mm	
BASE PLATE	100mm diameter Circular Base plate 4 x drilled drainage holes 10mm diameter 4 x drilled fixing holes 6mm diameter	

Wallbarn Ltd
Unit 16 Capital Business Centre
22 Carlton Road, South Croydon. CR2 0BS

IMS.T.967.v2

Optional Spreader Plate

The Spreader Plate is designed to significantly disperse weight and reduce point loading on vulnerable subfloors such as insulation or waterproof membranes ([Go to Test Report](#)).



Wing Nut Kit

Constructed from stainless steel, the M8 Wing Nut Kit meets Class A fire rating requirements. It is designed for use with the [MetalPad Ex](#) pedestal and securely attaches any Wallbarn aluminium joists to the pedestal's head.



Brackets/Connections for Aluminium Box Rail

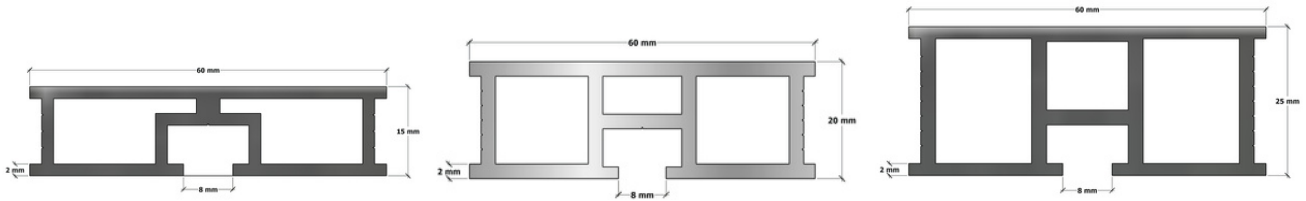

The Box Rail can be secured end to end or at right angles using brackets & screws supplied by Wallbarn.

Straight Bracket with Stainless Steel Screw



Right Angle Bracket with Stainless Steel Screw





I-Plus Rail Brackets

To join I-Plus Rails end to end, we designed stainless steel brackets that are secured with our stainless steel [Wing Nut Kits](#).



The same bracket as a right angle is also available to join the rails/joist together at right angles or when you wish to add noggins between rows of joists.



Wallbarn Ltd
Unit 16 Capital Business Centre
22 Carlton Road, South Croydon. CR2 0BS

IMS.T.967.v2

Phone : 020 8916 2222 Email : sales@wallbarn.com Website : www.wallbarn.com

W Clip for Fire Rated Decking

The W Clip is made from Aluminium which is powder coated and meets Class A rating. The W Clip also comes with the screws as part of the fixing.

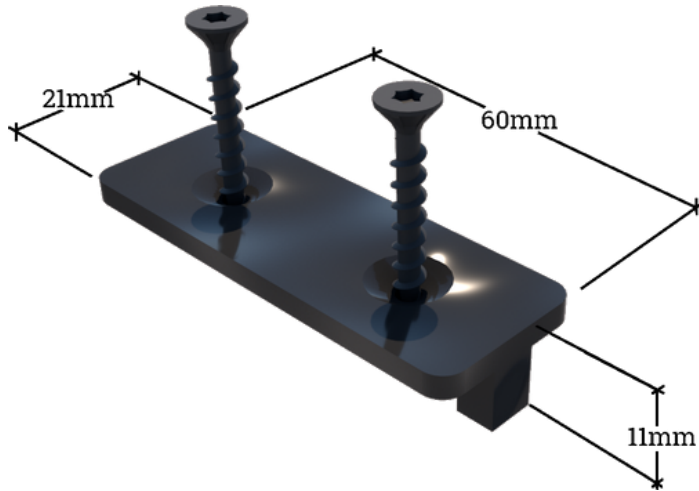



CUTTING AND DRILLING

For cutting metal components of the system, it is recommended to use premium blades specifically designed to cut metal. This helps minimize sparks and reduces the risk of damaging the extruded profile of each rail/joist. This is especially applicable when working on top of insulation and waterproofing membranes. Also note that damaged profiles may affect their ability to work seamlessly with our pedestals and/or headpieces. When cutting the Fire Deck - Fibre Cement Decking boards there is a specific blade available from Wallbarn that cuts clean and straight lines, minimising wastage and damage of the board.

When cutting any material, it's important to take certain precautions to ensure safety and achieve accurate cuts. Here are some precautions to consider:

1. Personal Protective Equipment (PPE): Wear appropriate PPE, including safety glasses or goggles, gloves, and a dust mask or respirator to protect your eyes, hands, and respiratory system from metal shavings, dust and cement particles.

2. Use the Right Tools: Ensure you have the correct tools for cutting aluminium or porcelain, such as a mitre saw, circular saw or a specialised cutting blades. Using the proper tools will help achieve clean and precise cuts.

3. Secure the Workpiece: Securely clamp the aluminium workpiece to prevent it from moving or vibrating during the cutting process. This will ensure stability and reduce the risk of accidents or inaccurate cuts.

4. Cutting Speed and Pressure: Maintain a steady cutting speed and avoid applying excessive force or pressure. Let the cutting blade do the work and allow it to cut through the aluminium at a controlled pace. Applying too much pressure can lead to rough cuts or blade damage.

5. Clear the Work Area: Prior to cutting any metal, it is important to clear the work area of clutter and unnecessary materials. When metal is being cut, sparks can be generated, so it is crucial to have a clean area free of debris to ensure fire safety. By removing any potential obstructions or hazards, you can create a safer environment during the cutting process.

6. Proper Waste Disposal: Collect and dispose of the aluminium shavings and waste material safely and appropriately. Aluminium shavings can be sharp and therefore has the potential to damage waterproofing membrane and/or insulation.



PRODUCT PERFORMANCE

Wallbarn's complete Class A Fire Deck System, if well maintained, is extremely long lasting with a product performance Limited Warranty of 15 years and expected lifespan of up to 50 years. With care and attention, the system can look and perform for many years beyond the warranty period. Please refer to the Limited Warranty details and conditions later in this manual.

The Fire Deck System is designed to maintain its shape and structural integrity when installed correctly as per the installation guide. To ensure optimal performance and to take full advantage of the warranty, we highly recommend using the complete system with all the individual components, supplied by Wallbarn as laid out in this manual. The components have been designed to work together whilst still having enough flexibility to overcome common obstacles encountered on site and at the time of installation.

MAINTENANCE DETAILS

Do's	Don't's
Keep your deck free of dirt and debris by regular sweeping (at least every 2 weeks) with a soft brush	Use sharp or abrasive materials to clean your deck (e.g. wire wool, abrasive papers or scrubbing tools). This may cause scratching of the coating which will affect the appearance.
Wash your deck down regularly with clean water and a mild detergent if required. We recommend a minimum of 2 times a year. Clean, wet surfaces can be allowed to air dry or can be wiped clean with a soft cloth.	Use abrasive salt grit for de-icing purposes. Instead, use easily soluble salt.
Use furniture with rubber or plastic feet to prevent unnecessary scratching of the decking surface.	Use aggressive acid or alkaline chemical to clean your deck.
Try to lift furniture or planters rather than drag them across the deck surface.	Use furniture with metal feet which can scratch the decking if dragged across the surface.
Check your decking carefully once a year to ensure no fixings are working loose, and simply tighten them using the appropriate driver bit if necessary.	Use oil/wax sealants, coatings, or polishes on the decking as this may cause the surface to become slippery, especially when wet.



MAINTENANCE DETAILS (cont'd)

How to Clean

SMC Peroxide Cleaner (available from Wallbarn) should be diluted with water and can be applied with a pump sprayer, watering can or mop/brush. When applying, saturate the affected material, then agitate the substrate with a nylon bristle brush to generate a profuse foam. Reapply a light coat of diluted SMC Peroxide Cleaner and let stand for 5 to 10 minutes. Agitate the substrate a final time and let stand for another 5 to 10 minutes. Use a clean water rinse to get the suspended dirt and debris away from the substrate. On deeply soiled materials an additional one or two applications may be necessary to restore the Fire Deck to its original look. The full brightening effects will be seen within 24 hours as the surface dries.

Special note: Only add SMC Peroxide Cleaner to application equipment that is clean and free of dirt and debris. Additionally, never return unused material to the original container that the SMC Peroxide Cleaner came from.

Storage of Cleaner: Store in a dry place at temperatures between 5°C and 25°C. Store securely closed and upright in the original container. Do not store in direct sunlight as this will reduce the potency of the product.

Avoid shipping or storing below freezing or above 37°C. If product freezes, thaw at room temperature and shake gently to remix components. Store in a locked area inaccessible to children.

****TEST PRODUCT ON A SMALL, INCONSPICUOUS AREA FIRST.**

****A detailed datasheet for this product is available from Wallbarn upon request.**

After Cleaning Sealant

1. ALWAYS TEST PRODUCT ON A SMALL AREA FIRST and allow a 24-hour cure time to check results.
2. Surface must be clean, dry and free of residues.
3. Generously apply Color Enhancing Sealer to a paint roller, clean brush or lamb's wool applicator. Avoid contact with surrounding areas.
4. Allow for a minimum of 30 minutes for product to penetrate the surface then thoroughly remove any excess product residue with clean, dry, white cloths, towels or similar. This starts the chemical reaction and must be done. Do not allow excess to sit on surface between coats.
5. Leave the product to cure for at least 60 minutes, then repeat steps 3 and 4. Total application rate is approximately 950ml per 2-25 sqm depending on surface absorption. A third coat may be required for premium stain protection on very porous surfaces.
6. Avoid contact with moisture for a minimum of 8 hours after application. Full curing takes 4 weeks.
7. Use an organic solvent for e.g. methylated spirits to clean equipment.



HAZARDS IDENTIFICATION

The major hazards associated with these products are primarily physical, with a focus on manual handling. It is important to note that sparks can be generated during cutting processes.

When working with aluminium, it is recommended to use high-quality saws and drills to minimize the production of particles and sparks. Even though aluminium is relatively easy to cut, using appropriate tools will help reduce the risk of sparks. To ensure safety, it is essential to wear proper protective clothing and equipment when handling and cutting aluminium.

This includes full coverage eye protection, which is particularly important. By utilizing the appropriate safety gear, you can mitigate the potential risks associated with handling and cutting aluminium.

FIRST-AID MEASURES

In case of cuts, it is important to thoroughly wash the wound with ample clean water. Afterward, it is advisable to seek immediate medical attention. Tetanus is a potential concern when working with metal, so prompt medical evaluation is crucial.

If you experience skin, eye, or respiratory irritation, it is important to seek medical attention as soon as possible. This is especially necessary if you are experiencing any eye irritation.

Prompt medical evaluation will help address any potential issues and ensure appropriate treatment for the symptoms you are experiencing.

FIRE-FIGHTING MEASURES

The Fire Deck system achieves fire resistance Class A according to standard BS EN 3501-01 : 2018, so it poses no fire risk. Therefore, it can be easily installed in public areas and does not constitute a fire hazard. Use extinguishing media appropriate to the surrounding fire conditions.

HAZARD

As supplied, the products are not classified as hazardous.



HANDLING AND STORAGE

When handling the different components of this system, it is essential to consider the risks outlined in the Manual Handling Operations Regulations 1992, and appropriate personal protective equipment (PPE) should be used. The system will be delivered secured onto pallets, and it is important to utilize suitable lifting equipment such as forklifts and cranes, operated by qualified personnel when moving the pallets.

To ensure safe storage, all components should be stored in a stable manner. It is recommended to store them as they were delivered (on Pallets) and placed in secure area.

During the cutting process, it is crucial to implement measures to control metal particles and ensure proper ventilation. Additionally, always wear appropriate respiratory and full covered eye protection to safeguard against potential hazards.

DISPOSAL CONSIDERATIONS

Recycling the system at the end of their life cycle is strongly recommended. Aluminium and Steel is a highly recyclable material, and recycling helps conserve resources and reduce environmental impact. By recycling all components, the material can be processed and used to create new products.

When it comes to the disposal of the system, it can be taken to an approved solid waste disposal site. These sites are equipped to handle various types of waste materials, including metals.

It is important to note that the disposal process should adhere to local or national regulations. Different regions may have specific guidelines and requirements for the disposal of certain materials. These regulations are in place to protect the environment and human health.

To ensure compliance, it is recommended to consult the relevant local or national authorities or waste management agencies for specific guidance on the proper disposal of aluminium rails. They can provide information on designated disposal facilities, recycling programs, or any special instructions that need to be followed.

By following the appropriate local or national regulations for disposal, you can contribute to responsible waste management and help minimize the environmental impact.



WARRANTIES

A Limited Warranty exists that the products will comply with the test data as laid out in this document for a period of 15 Years. Warranty is limited to replacement of products which have been installed in the correct manner and for the correct purpose only. Warranty is limited to the value of the cost price of the materials only, not replacement costs or any other labour cost.

Under no circumstances shall Wallbarn Ltd be held responsible or liable for any incidental, consequential, indirect, special, punitive or any other damage (including, but not limited to, loss of profits, loss of sales, loss of start-up, loss or reduction of work).

The lifespan of the Class A Fire Deck System is expected to be up to 50 Years. The Limited Warranty covers all the components on condition that the Installation and Care & Maintenance Instructions are followed, and the system is installed according to Wallbarn Ltd guidelines.

See Terms and Conditions of the Warranty and Scope of the Guarantee below for other exclusions and limitations of this Warranty.

1) WARRANTY TERMS AND CONDITIONS

1.1 Complaints are physically examined by Wallbarn Ltd.

1.2 Complaints / claims should be filed in writing to Wallbarn Ltd.

1.3 Proof of purchase of the rails/joists should accompany the written complaint / claim. Complaints / claims without the appropriate documentation will not be considered.

1.4 The company examining complaints (or its representatives) reserves the right to check the system in the place of installation, the manner they have been installed and obtain details of the care and maintenance programme carried out before giving consideration to the complaint / claim.

1.7 The complaint / claim is only valid if the products are installed in the territory that the original purchase was made.

1.8 Wallbarn Ltd reserves the right to either repair the defect or to offer material free of charge to the customer.

The above guaranteed lifetime of the Products "Fire Deck System" exists only where the Products have been installed in the correct and proper manner.



2) VISUAL APPEARANCE WARRANTY ON DELIVERY

Each component is carefully inspected by our quality control team before leaving our factory to ensure it is free from defects. We urge customers and installers to thoroughly inspect all components prior to installation. This Limited Warranty does not cover defects discovered after installation has taken place.

3) SCOPE OF GUARANTEE

3.1 This guarantee is issued in accordance with and is subject to the laws of England & Wales.

3.2 Obvious defects in the components must be reported to the supplier within 30 days from the delivery date to the site or warehouse. Claims regarding obvious defects submitted after this period will not be considered.

3.3 To be able to make use of the Warranty - the product – Fire Deck System must be installed according to the Installation Instructions. Use fixings recommended and approved by Wallbarn Ltd as indicated in the appropriate technical documentation. The use of other types of fixtures not provided or approved by Wallbarn Ltd invalidates this Warranty.

3.4 If a claim is granted before installing the material, faulty components are replaced free of charge.

3.5 No claims can be accepted after installing the material if the buyer could have detected the defects before installation. This Warranty does not cover damage caused by third parties before installation.

TRANSPORT INFORMATION

The best method of transportation is strapped securely onto pallets.



KEY CONTACTS

Wallbarn Ltd.

Unit 16 CapitalBusiness Centre, 22 Carlton Road, South Croydon CR2 0BS

Tel: +44 (0)20 8916 2222

Fax: +44 (0)20 8916 2223

Email: sales@wallbarn.com

Web: www.wallbarn.com

APPENDIX A:

The following table summarizes the documents and URLs referenced in this document:

Document Name	Location
Fire Deck	https://www.wallbarn.com/cement-fibre/c-deck-cement-fibre-decking/
MetalPad Ex Pedestal	https://www.wallbarn.com/fire-rated/metalpad-ex/
Class A Substructure	https://www.wallbarn.com/substructure/class-a1-rail-substructure-system/
Aluminium Box Joist/Rail	https://www.wallbarn.com/substructure/box-rail/
Aluminium I-Plus Joist/Rail	https://www.wallbarn.com/substructure/i-plus-beam/
W Clip Hidden Deck Fixing	https://www.wallbarn.com/decking-clips-fittings/wing-clip-60/
Spreader Plate	https://www.wallbarn.com/fire-rated/headpieces-fixings/spreader-plate/

Wallbarn Ltd
Unit 16 Capital Business Centre
22 Carlton Road, South Croydon. CR2 0BS

IMS.T.967.v2

Phone : 020 8916 2222 Email : sales@wallbarn.com Website : www.wallbarn.com



APPENDIX B:

LIMITED WARRANTY

Wallbarn Ltd provides a limited warranty of 15 years for products. This Warranty corresponds to the performance and strength characteristics given in the published technical datasheets.

Wallbarn Ltd warrants that, under normal use and service conditions, and where the products have been installed in the proper manner, Wallbarn Ltd products shall be free from material defects in workmanship and materials, shall not crack, splinter, swell, rot or suffer structural damage from damp or fungal decay.

If a defect occurs within the Warranty Period, the Purchaser shall notify Wallbarn Ltd in writing and, after investigation and confirmation of the defect(s) by a Wallbarn Ltd representative, Wallbarn Ltd's sole responsibility shall be limited to replacement of the affected products or to refund the Purchaser up to the maximum value of the Sales Invoice.

This warranty is null and void if:

- The products are not installed in the proper manner as detailed in official Wallbarn Ltd product catalogues, installation guides and technical datasheets.
- The products are not used for the purposes they are intended, as detailed in official Wallbarn Ltd product catalogues, installation guides and technical datasheets.
- Excessive weights, higher than the maximum weight as detailed in official Wallbarn Ltd product catalogues, installation guides and technical datasheets are placed onto the products.
- The products are installed in contravention of any relevant building regulations, code or standards.
- Any relevant building regulations, code or standards, including fire safety regulations are breached on the project during the construction process.
- There is movement, distortion, collapse or settling of the supporting structure on which Wallbarn Ltd products are installed.
- Any abnormal natural event such as flooding, hurricane, earthquake, lightning, etc., occurs.



Wallbarn Ltd – Limited Warranty

This limited warranty does not cover any living product or any product which sustains life. This includes sedum and other plants and substrate mixes for M-Tray® and any other green roof system. The living and growing elements of M-Tray® and other green roof systems are specifically excluded from this Warranty.

This Warranty is limited to the maximum amount of the Sales Invoice and Wallbarn Ltd is not liable for any costs of examination, removal or installation of products. Wallbarn Ltd will not be responsible for any costs or expenses incurred during removal and replacement, including labour or transport costs.

This warranty is given only if the products are used for the purposes they are intended, as detailed in official Wallbarn Ltd product catalogues, installation guides and technical datasheets and are installed in the correct manner.

To make a claim under this Limited Warranty, the Purchaser should contact Wallbarn Ltd with a full report of the defects within the Warranty Period, including photographic evidence and proof of purchase. Any claim should be made to sales@wallbarn.com as soon as possible by the Purchaser.

Our Terms & Conditions of Supply can be found here
<https://www.wallbarn.com/terms-conditions-of-supply/>

APPENDIX C:

TEST CERTIFICATE

LOAD TESTING IN ACCORDANCE WITH THE CLIENT'S SPECIFICATION



On Wallbarn Limited,
3 Hagley Court North, The Waterfront, Dudley, West Midlands, DY5 1XF

PROOF LOAD TESTING STS LABORATORY

TEST DESCRIPTION: A weight tolerance test was conducted on various pedestals. Testing was completed using a jack to apply a vertical compressive load centre to the product, to confirm structural performance and determine load failure limit. All testing was carried out in accordance with the client's specification.

REF NO.:	DR-5744	DATE TESTED:	15 th May 2024
JOB NO.:	P10259	CERTIFICATE DATE:	24 th May 2024
CERTIFICATE NO.:	IC11714	SUPPLIER/SOURCE:	Client

TEST DETAILS:			
Product Tested:	Various Pedestal Samples (See table Below)	Item Condition:	New
Target Loads:	Failure	Ambient Temperature:	18°C
Test Location:	STS Laboratory	Procedure or Method:	Client's Specification

TEST RESULTS:

Test Product	Product Material	Load Achieved (kN)
26 – 35mm Pedestal	Steel	53.67
185 – 260mm Pedestal	Steel	49.86
26 – 35mm Pedestal with Spreader Plate	Steel	70.69
185 – 260mm Pedestal with Spreader Plate	Steel	129.53
10mm Fixed Height Pad	Aluminium	209.24

ANALYSIS:

Testing was completed with each individual pedestal obtaining failure loads. Following this, the highest load achieved at failure was the 10mm Fixed Height Pad, achieving a load of 209.24kN before failure. The 185 – 260mm Pedestal obtained the lowest load achieved, with 49.86kN before the product began to deform. All testing was completed within the client's specification.

For Specialist Technical Services (U.K) Limited		The results found on this Certificate relate only to the product[s] tested as described above This Test Certificate shall <u>not</u> be reproduced except in full QC: TC001 – Test Certificate – v4.0 Page 1 of 1
Approved By: Andrew Gore		
Position: Technical Director		
Signature:		

END OF PAGE



APPENDIX D:

TEST CERTIFICATE
LOAD TESTING IN ACCORDANCE WITH
THE CLIENT'S SPECIFICATION



On Wallbarn Limited,
3 Hagley Court North, The Waterfront, Dudley, West Midlands, DY5 1XF

PROOF LOAD TESTING
STS LABORATORY

TEST DESCRIPTION: A weight tolerance test was conducted on various aluminium rails to determine the destructive load obtainable. Testing was completed using a jack to apply a vertical compressive load centre to the product, to confirm structural performance and determine load failure limit. All testing was carried out in accordance with the client's specification.

REF NO.:	DR-5744	DATE TESTED:	15 th May 2024
JOB NO.:	P10259	CERTIFICATE DATE:	24 th May 2024
CERTIFICATE NO.:	IC11717	SUPPLIER/SOURCE:	Client

TEST DETAILS:			
Product Tested:	Aluminium Rail	Item Condition:	New
Target Loads:	Failure	Ambient Temperature:	18°C
Test Location:	STS Laboratory	Procedure or Method:	Client's Specification

TEST RESULTS:

Test Product	Load Obtained (kN)	Maximum Displacement (mm)
15mm Rail	1.05	68.77
20mm Rail	1.06	65.87
25mm Rail	1.58	64.63
50mm Rail	4.08	44.96
75mm Rail	6.58	32.65
100mm Rail	8.10	27.86

ANALYSIS:

Testing was completed with each individual rail obtaining various loads before reaching failure. The 15mm rail obtained the lowest load (1.05kN) along with the highest displacement (68.77mm), with the 100mm obtaining the highest loading (8.10kN) along with the lowest recorded displacement (27.86mm). All testing was completed within the client's specification.

For Specialist Technical Services (U.K) Limited		The results found on this Certificate relate only to the product[s] tested as described above This Test Certificate shall <u>not</u> be reproduced except in full QC: TC001 – Test Certificate – v4.0 Page 1 of 1
Approved By: Andrew Gore		
Position: Technical Director		
Signature:		

END OF PAGE

Unit D4, Poole Hall Business Park, Poole Hall Road, Ellesmere Port, Cheshire, CH66 1UA, United Kingdom

T: +44 (0) 1244 794 104 F: +44 (0) 1244 794 204

E: info@sts-group.co.uk

Offices Located at: Chester | Ellesmere Port

Website: <https://www.sts-group.co.uk>



APPENDIX E:

TEST CERTIFICATE

LOAD TESTING IN ACCORDANCE WITH BS 8579:2020



On Wallbarn Limited, 3 Hagley Court North, The Waterfront, Dudley, West Midlands, DY5 1XF

PROOF LOAD TESTING STS LABORATORY

TEST DESCRIPTION: A weight tolerance test was conducted on various aluminium rails fitted to steel pedestals, increasing in 100mm spans from the centre of the rail. Testing was completed using a jack to apply a vertical compressive load centre to the product, to confirm structural performance. Loading results obtained were recorded at the limit of 5mm deflection. All testing was carried out in accordance with the client's specification.

REF NO.: DR-5744 DATE TESTED: 15th May 2024
JOB NO.: P10259 CERTIFICATE DATE: 24th May 2024
CERTIFICATE NO.: IC11716 SUPPLIER/SOURCE: Client

TEST DETAILS: Product Tested: Aluminium Rail with Steel Pedestal Item Condition: New
Target Loads: 5mm Deflection Ambient Temperature: 18°C
Test Location: STS Laboratory Procedure or Method: BS 8527:2020

TEST RESULTS:

Table with columns: Test Product, Load Achieved (kN) (100mm from Centre to 1200mm from Centre), and rows for 15mm Rail, 20mm Rail, 50mm Rail, 75mm Rail, and 100mm Rail.

ANALYSIS:

Testing was completed with each individual rail obtaining various loads before reaching 5mm deflection. The 15mm & 20mm rail reached a 400mm span before the maximum deflection was obtained, with the 100mm rail reaching a span of 1200mm from the centre, before obtaining maximum permissible deflection. All testing was completed within the BS 8572:2020.

Table with signature and approval details for For Specialist Technical Services (U.K) Limited, including Approved By: Andrew Gore, Position: Technical Director, and QC: TC001 - Test Certificate - v4.0 | Page 1 of 1

END OF PAGE





**FIRE PROOF A1 RATED
NON-COMBUSTIBLE
DECKING**

WDa20191225001a4

2440 x 190 x 25mm

TEST ITEM

5 minutes. Uniform load test:
The vertical downward uniform load is applied to two trestle slab specimens, and the load is loaded to failure at different stages for five minutes. The deformation in the middle span position is read and the failure condition of the specimen is recorded.

BRIEF DESCRIPTION OF THE DEVICE

The two trestle plate specimens are carried together, the trestle plate is fastened and installed on the skeleton with self-tapping screws, the skeleton is fastened to the rigid support, the test net span is 400mm, and the test surface width is 190x3 = 380mm. Install the meter at both ends of the middle bottom of the specimen and the data of sinking deformation is read.

TEST RESULTS

Applied Load Value (Kilos)	Applied Load Value (kN)	Average Value of Mid-span Deformation (m m)
0.00	0.00	0.00
101.97	1.00	0.187
203.94	2.00	0.355
305.91	3.00	0.529
407.89	4.00	0.716
509.86	5.00	0.912
611.83	6.00	1.116
713.80	7.00	1.307
815.77	8.00	1.498
866.76	8.50	1.593
917.74	9.00	1.687
968.73	9.50	1.825
1019.72	10.00	1.946
1070.70	10.50	2.068
1121.69	11.00	2.199
1172.67	11.50	2.333
1223.66	12.00	2.489
1274.65	12.50	2.625
1325.63	13.00	2.826
1331.75	13.06	Termination of Trial





**FIRE PROOF A1 RATED
NON-COMBUSTIBLE
DECKING**

WDa20191225001a4

2440 x 190 x 25mm

TEST ITEM

5 minutes. Uniform load test:
The vertical downward uniform load is applied to two trestle slab specimens, and the load is loaded to failure at different stages for five minutes. The deformation in the middle span position is read and the failure condition of the specimen is recorded.

BRIEF DESCRIPTION OF THE DEVICE

The two trestle plate specimens are carried together, the trestle plate is fastened and installed on the skeleton with self-tapping screws, the skeleton is fastened to the rigid support, the test net span is 400mm, and the test surface width is 190x3 = 380mm. Install the meter at both ends of the middle bottom of the specimen and the data of sinking deformation is read.

TEST RESULTS

Applied Load Value (Kilos)	Applied Load Value (kN)	Average Value of Mid-span Deformation (m m)
0.00	0.00	0.00
101.97	1.00	0.187
203.94	2.00	0.355
305.91	3.00	0.529
407.89	4.00	0.716
509.86	5.00	0.912
611.83	6.00	1.116
713.80	7.00	1.307
815.77	8.00	1.498
866.76	8.50	1.593
917.74	9.00	1.687
968.73	9.50	1.825
1019.72	10.00	1.946
1070.70	10.50	2.068
1121.69	11.00	2.199
1172.67	11.50	2.333
1223.66	12.00	2.489
1274.65	12.50	2.625
1325.63	13.00	2.826
1331.75	13.06	Termination of Trial

